

## GS EVO LOW FORKS 20S4 1150X525

Lowered height to handle special pallets



### GS EVO LOW FORKS

The GS EVO is the top choice for hand pallet truck, designed for an intensive use with maximum easiness of use and superior ergonomics.

This special GS EVO Low Profile is designed to easily operate where the pallet has a limited access due to height. With only **55 mm** height from the ground, it is suitable to handle pallets with very low clearance openings.

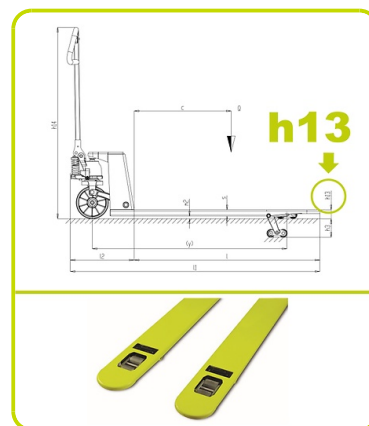

### TILLER

3D Superior Ergonomic shape tiller. This tiller has a special 3D design, with enhanced ergonomics. Compared to a conventional tiller, this shape allows the operator to have a good position when pushing the loads with maximum efficiency without fatigue. This thanks to two large grasping side areas specifically designed to have a correct position during operation of the truck.



## HYDRAULIC UNIT

The GS EVO pump has been designed with extreme care of details in order to have superior characteristics and features, such as:

- **Monolithic design:** the resistant and reliable one-piece cast iron housing protects all components avoiding any accidental damages. Pump housing is processed with CNC machines to achieve high precision tolerances and high accuracy.
- **Chromed piston rod and oil seal:** in order to avoid rust and prevent oil leakage during the use.
- **Maximum pressure valve:** safety device that protects the transpallet against overloads.
- **PROPORTIONAL LOWERING VALVE:** lowering speed can be proportionally controlled according to the lever position on the tiller. Perfect working tool to carry fragile and delicate loads like crystal, glass and ceramics.



## VARNISHING

Following an appropriate conditioning operation the frame is varnished with polyester powder at a temperature of 250° to guarantee maximum resistance to wear and atmospheric agents.



## EASY TO MOUNT

Tiller easy to assemble with a fast mounting system. Robust tiller connection with two full welded joints that assure superior sturdiness in the toughest application.



## Description

1.1 Manufacturer			LIFTER
1.3 Drive			Manual
1.4 Operator type			Pedestrian
1.5 Load capacity	Q	Kg	2000
1.6 Load centre distance	c	mm	600
1.8 Load axle to end forks	x	mm	945
1.9 Wheel base	y	mm	1192

## Weights

2.1 Service weight		Kg	71
2.2 Axle load, laden rear		Kg	1378
2.2 Axle load, laden front		Kg	693
2.3 Axle load, unladen rear		Kg	23
2.3 Axle load, unladen front		Kg	48

## Tyres/Chassis

3.1 Tyres: front wheels			POLY.I./ NYLON
3.1 Tyres: rear wheels			STEEL
3.2 Tyre size: Steering wheels - Diameter	mm		200
3.2 Tyre size: Steering wheels - Width	mm		45
3.3 Tyre size: Load rollers - Diameter	mm		55
3.3 Tyre size: Load rollers - Width	mm		58
3.5 Tyre size: rear wheels - Q.ty (X=driven)	nr		4
3.5 Rear balancing axle			No
3.6 Tread, front	b10	mm	125
3.7 Tread, rear	b11	mm	365

## Dimensions

4.4 Lift height	h3	mm	115
4.9 Height of tiller in drive position max	h14	mm	1185
4.9 Height of tiller in drive position min	h14	mm	710
4.15 Height, lowered	h13	mm	55
4.19 Overall length	l1	mm	1550
4.20 Length to face of forks	l2	mm	400
4.21 Overall width	b1	mm	525
4.22 Fork dimensions - Thickness	s	mm	40
4.22 Fork dimensions - Width	e	mm	160
4.22 Fork dimensions - Length	l	mm	1150
4.25 Distance between fork arms	b5	mm	525
4.32 Ground clearance, centre of wheelbase	m2	mm	15
4.34 Aisle width	Ast	mm	2041
4.35 Turning radius	Wa	mm	1367

## Performance data

5.2 Lifting speed laden	strokes		12
5.2 Lifting speed unladen	strokes		12

